

Copyright © 2019 by Big Bike Parts, Inc. No part of this instruction sheet may be reproduced without the written permission of Big Bike Parts, Inc.

PART NO. 41-401/41-401BK**MINI LED LIGHT KIT**

11/1/2019

FITMENT: CAN-AM RYKER 2019-NEWER

TOOLS NEEDED:	2MM ALLEN WRENCH	4MM ALLEN WRENCH	5MM ALLEN WRENCH	10MM WRENCH	13MM WRENCH
	DRILL	13/16" DRILL BIT	FLAT BLADE SCREWDRIVER	WIRE CRIMPER/CUTTER	REMOVABLE THREAD LOCK
	JACK/RAMPS	MASKING TAPE	PEN OR FINE TIP MARKER	T30 TORX DRIVER	

**PLEASE READ THROUGH AND UNDERSTAND THESE INSTRUCTIONS BEFORE BEGINNING. USE REMOVABLE THREAD LOCK ON ALL SCREWS.
ESTIMATED INSTALLATION TIME: 60 TO 90 MIN.**

INSTALLATION:

1. REMOVE THE TWO MINI LIGHTS FROM THE KIT. USING A 2MM ALLEN WRENCH REMOVE THE THREE SMALL SET SCREWS. INSTALL THE LED BULB. APPLY A SMALL DROP OF REMOVABLE THREAD LOCK TO EACH SET SCREW AND REINSTALL THE SET SCREWS. CLEAN OFF ANY EXTRA THREAD LOCK.
2. USING A JACK OR RAMPS LIFT THE FRONT OF THE RYKER HIGH ENOUGH TO WORK ON THE UNDER SIDE OF THE FRONT.
3. USING A T30 TORX DRIVER REMOVE THE TWO BOLTS SHOWN IN **FIG. 1**. *NOTE: THESE BOLTS WILL NOT BE REUSED.*
4. INSTALL THE TWO M6 CLIP NUTS ON THE FRAME OF THE RYKER AS SHOWN IN **FIG. 2**.
5. USING **FIG. 3** FOR REFERENCE REMOVE THE RIGHT MOUNT FROM THE KIT.
6. USING YOUR HAND PULL THE PLASTIC BODY PANEL DOWN AND SLIDE THE RIGHT MOUNT BETWEEN THE PANEL AND THE FRAME. SEE **FIG. 4**.
7. LINE THE HOLES UP WITH THE CLIP NUT AND THE OEM HOLE YOU REMOVED THE SCREW FROM IN STEP 3.
8. INSTALL ONE OF THE SUPPLIED M6 SCREWS THROUGH THE BODY PANEL AND THROUGH THE MOUNT AND INTO THE OEM NUT USING ONE OF THE LARGE FENDER WASHERS AND A LOCK WASHER. SEE **FIG. 3**.
9. INSTALL ANOTHER SCREW WITH A FLAT WASHER AND A LOCK WASHER THROUGH THE MOUNT AND INTO THE NEW CLIP NUT. SEE **FIG. 3**.
10. REPEAT STEPS 3 THROUGH 9 FOR THE LEFT MOUNT.
11. INSTALL THE MINI LIGHTS ON THE MOUNTS. *NOTE: THE EXTRA HOLES IN THE MOUNTS ARE FOR USING WIRE TIES TO SECURE THE WIRES.*
12. REMOVE THE FRONT HOOD AND ON THE LEFT SIDE REMOVE THE CVT AIR CLEANER COVER. SEE **FIG. 5**.
13. PLACE A PIECE OF MASKING TAPE ON THE CVT AIR CLEANER COVER AS SHOWN IN **FIG. 5**.
14. USING A PENCIL MARK THE LOCATION SHOWN IN **FIG. 5**.
15. DRILL A 13/16" HOLE THROUGH THE PLASTIC IN THE LOCATION YOU MARKED. (BBP RECOMMENDS USING A STEP DRILL FOR PLASTIC)
16. INSERT THE SUPPLIED ROUND SWITCH INTO THE HOLE.
17. DISCONNECT BOTH THE POSITIVE AND NEGATIVE CABLES FROM THE BATTERY.
18. USING THE TWO LONG BLACK WIRES SUPPLIED CONNECT ONE WIRE FROM EACH LIGHT TO THE SUPPLIED RELAY. CONNECT THE OTHER WIRE FROM EACH LIGHT TO A GROUND ON THE RYKER. SEE **FIG. 6**.
19. TAKE THE THREE WIRE HARNESS WITH THE BLUE, ORANGE, AND GREEN WIRES FROM THE KIT AND FEED THE END WITH THE THREE SPADE CONNECTORS THROUGH TO THE NEW SWITCH FROM FRONT.
20. CONNECT THE THREE WIRES AS SHOWN IN **FIG. 6**.
21. CONNECT THE BLUE WIRE FROM THE SWITCH TO THE RELAY. SEE **FIG. 6**.
22. CONNECT THE ORANGE WIRE TO A KEYED POSITIVE WIRE ON THE RYKER USING THE T-TAP SUPPLIED WITH THE KIT.
23. ROUTE THE GREEN WIRE TO A GROUND ON THE RYKER.
24. TAKE THE HARNESS WITH THE RED AND THE GREEN WIRES AND CONNECT THE SPADE CONNECTORS TO THE RELAY. SEE **FIG. 6**.
25. ROUTE THE RED WIRE TO THE POSITIVE TERMINAL AND THE GREEN WIRE TO THE NEGATIVE TERMINAL ON THE RYKERS BATTERY.
26. RECONNECT THE POSITIVE TERMINAL ON THE BATTERY INCLUDING THE NEW RED WIRE FROM THE RELAY.
27. RECONNECT THE NEGATIVE TERMINAL ON THE BATTERY INCLUDING BOTH NEW GREEN WIRES.
28. USING A WIRE TIE SECURE THE RELAY TO THE RYKER. USE WIRE TIES TO SECURE ALL OF THE WIRING TO THE RYKER.
29. TURN THE RYKER ON AND TEST THE FUNCTION OF BOTH LIGHTS.
30. REASSEMBLE THE FRONT HOOD AND CVT AIR CLEANER COVER AND LOWER THE RYKER TO THE GROUND.
31. ADJUST LIGHTS AS NEEDED AND MAKE SURE ALL HARDWARE IS TIGHT.
32. AFTER A SHORT RIDE RECHECK ALL FASTENERS AND MAKE SURE WIRING IS SECURE.

FIG. 1

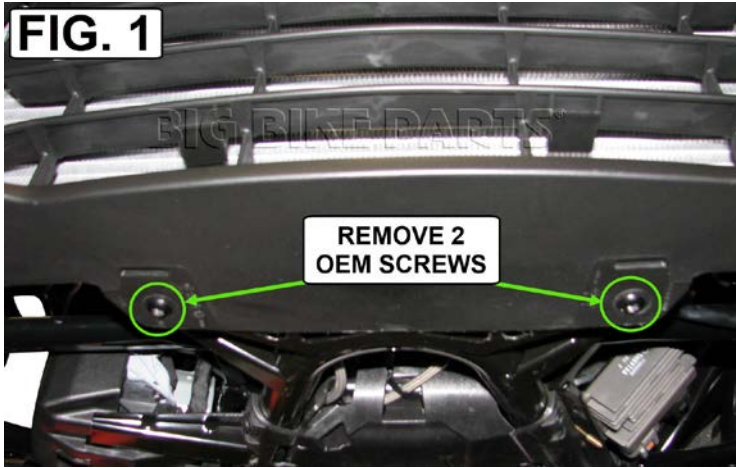

FIG. 2

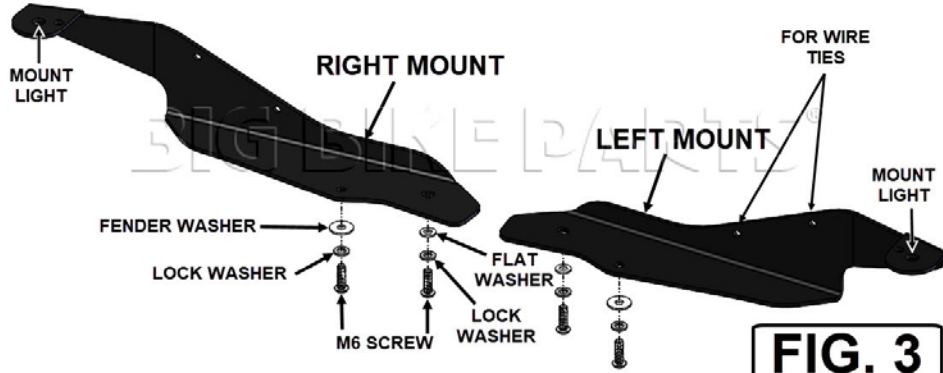
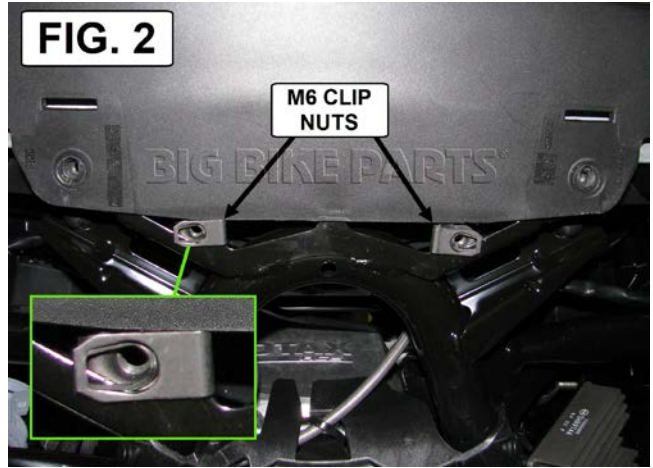

FIG. 3

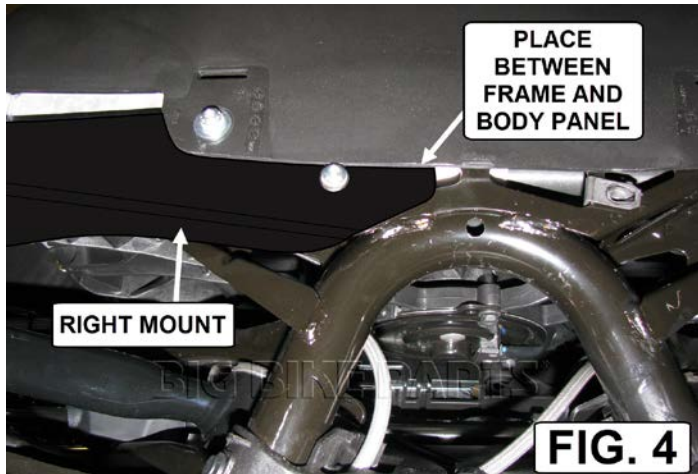

FIG. 4



FIG. 5

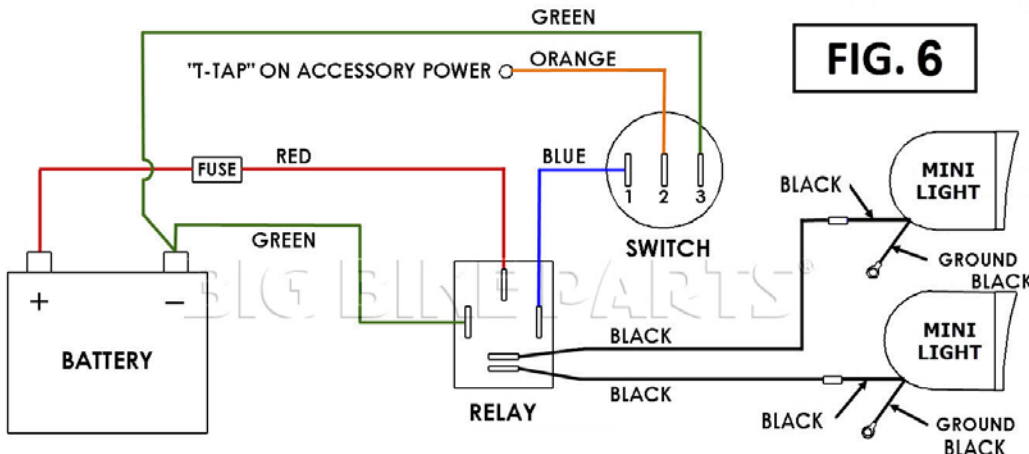

FIG. 6



STEP DRILL