

Packing • Boxes 300 pcs. • Pallets 7.200 pcs.

Logica Packing • Boxes 150 pcs. • Pallets 3.600 pcs.

Use these formulas to determine the type of hinge arm, the drilling distance "K" and the height of the mounting plate "H" which is necessary to solve each application problem.

Use the tables "Drillings and fixings" at page 21 to complete the code number of the desired hinge.

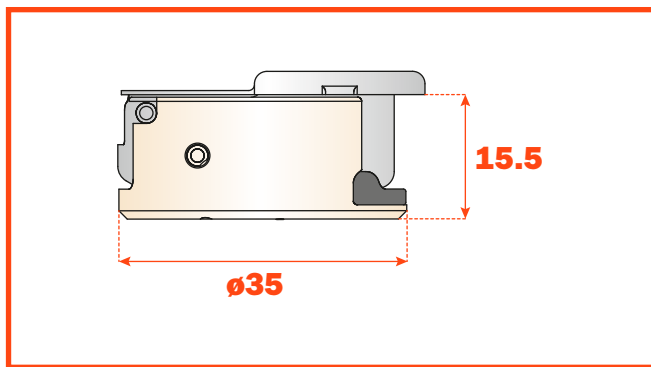

Arm 0

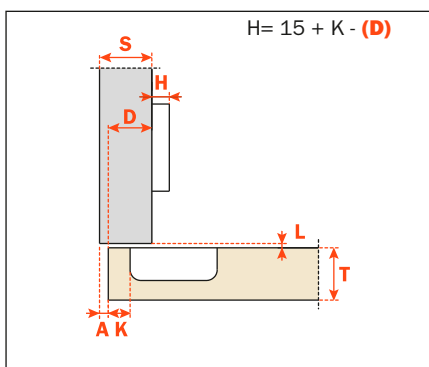

C2_BAE9

Arm 5

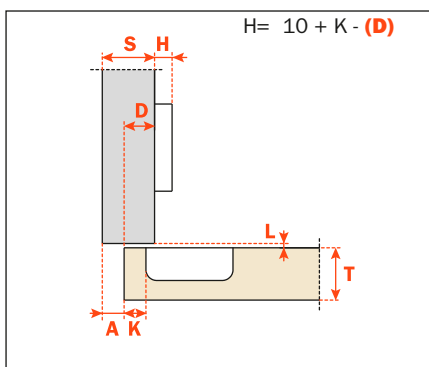

C2_BDE9

Arm 9

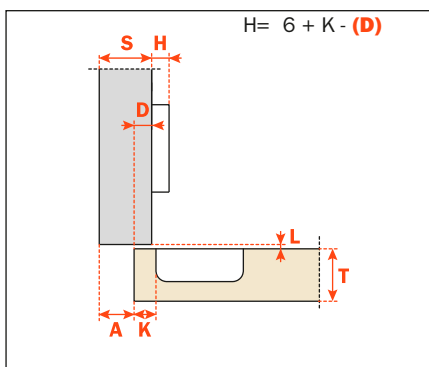

C2_BGE9

Arm 17

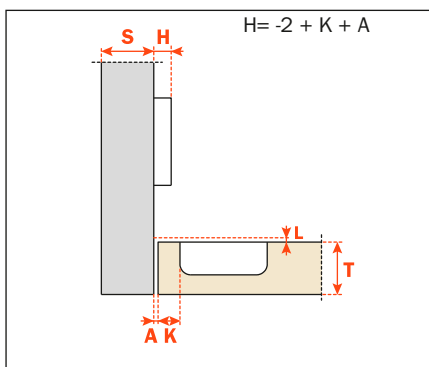

C2_BPE9